

# NAIL FIN INSTALLATION

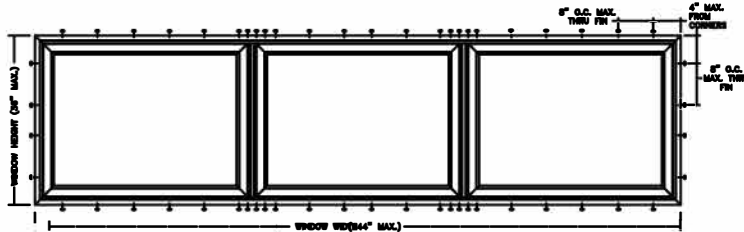

TYPICAL ELEVATION WITH FASTENER SPACING

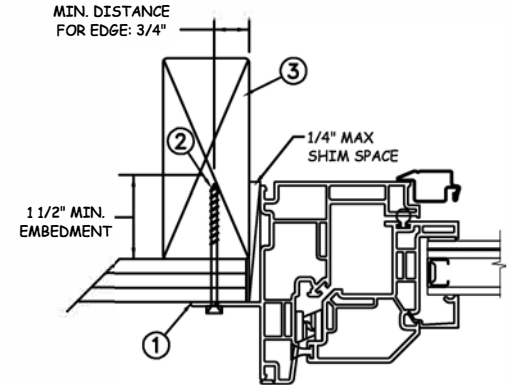
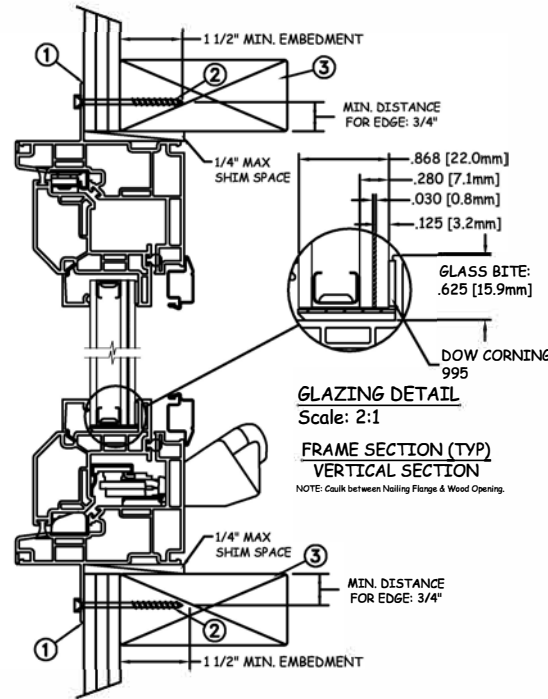

JAMB SECTION (TYP)  
HORIZONTAL SECTION

NOTE: Caulk between Nailing Flange & Wood Opening.

Max Frame	DP RATING	IMPACT
144 x 36	+50/-55	YES

WINDZONE 2

### Installation Notes:

1. Seal flange/frame to substrate.
2. Use #8 PH or greater fastener through the nail fin with sufficient length to penetrate a minimum of 1 1/2" into the wood framing. For 2X wood frame substrate (min. S.G. = 0.42).
3. Host structure (wood buck, masonry, steel) to be designed and anchored to properly transfer all loads to the structure. The host structure is the responsibility of the architect or engineer of record for the project of installation.

### General Notes:

1. The product shown herein is designed, tested and manufactured to comply with the wind load criteria of the adopted International Building Code(IBC), the International Residential Code(IRC), the Florida Building Code (FBC) excluding HVHZ and the industry requirement for the stated conditions.
2. All glazing shall conform to ASTM E1300.
3. At minimum, glazing shall be 3.2mm annealed - 11.8mm airspace - 3.2mm annealed - 0.8mm PVB Interlayer by Kurraray - 3.2mm annealed insulating glass.
4. Use structural or composite shims where required.

This schedule addresses only the fasteners required to anchor the window to achieve the rated design pressure up to the size limitations noted. It is not intended as a guide to the installation process and does not address the sealing consideration that may arise in different wall conditions. For the complete installation procedure, see the instructions packaged with the window or go to [www.jeld-wen.com](http://www.jeld-wen.com).

### DISCLAIMER:

This drawing and its contents are confidential and are not to be reproduced or copied in whole or in part or used or disclosed to others except as authorized by JELD-WEN Inc.



PROJECT ENGINEER: ---	DATE: 11/16/17	<b>JELD WEN</b> 3737 Lakeport Blvd Klamath Falls, OR. 97601 Phone: (800) 535-3936
DRAWN BY: A. MCMILLAN	SCALE: NTS	
CHECKED BY: J. GOOSSEN	TITLE: Premium Vinyl Awning Impact Window XXX - WZ2	
APPROVED BY: J. GOOSSEN		
PART/PROJECT No.:		
D014415		
IDENTIFIER No. 110-17-041	PLANT NAME AND LOCATION:	CAD DWG. No.:
		REV: A
		SHEET 1 OF 4

## THROUGH FRAME INSTALLATION

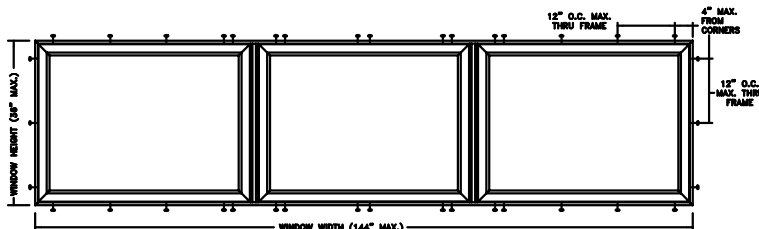

TYPICAL ELEVATION WITH FASTENER SPACING

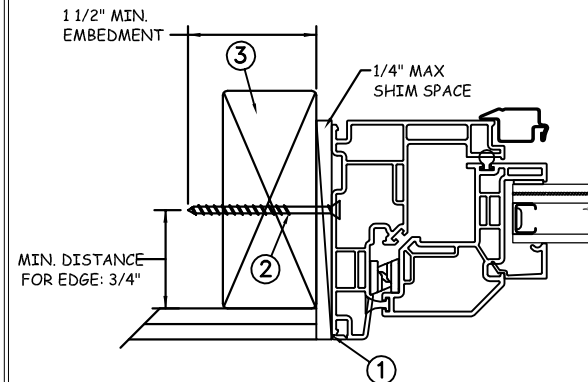
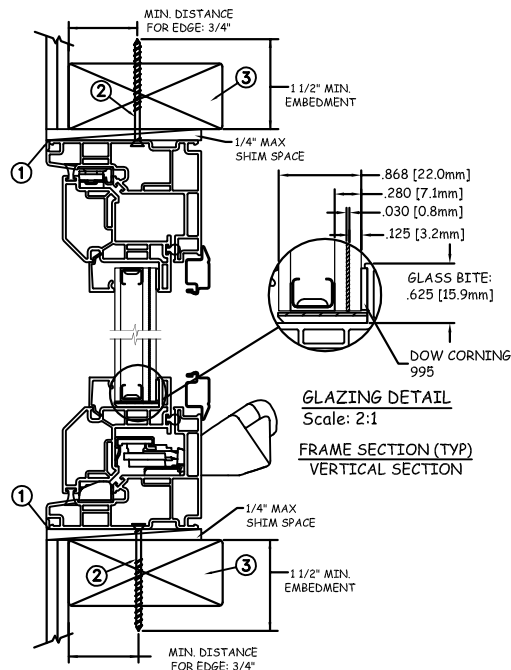

JAMB SECTION (TYP)  
HORIZONTAL SECTION

Max Frame 144 x 36	DP RATING +50/-55	IMPACT YES
-----------------------	----------------------	---------------

WINDZONE 2

### Installation Notes:

1. Seal flange/frame to substrate.
2. Use #8 PH or greater fastener through the frame with sufficient length to penetrate a minimum of 1 1/2" into the wood framing. For 2X wood frame substrate (min. S.G. = 0.42).
3. Host structure (wood buck, masonry, steel) to be designed and anchored to properly transfer all loads to the structure. The host structure is the responsibility of the architect or engineer of record for the project of installation.

### General Notes:

1. The product shown herein is designed, tested and manufactured to comply with the wind load criteria of the adopted International Building Code(IBC), the International Residential Code(IRC), the Florida Building Code (FBC) excluding HVHZ and the industry requirement for the stated conditions.
2. All glazing shall conform to ASTM E1300.
3. At minimum, glazing shall be 3.2mm annealed - 11.8mm airspace - 3.2mm annealed - 0.8mm PVB Interlayer by Kurraray - 3.2mm annealed insulating glass.
4. Use structural or composite shims where required.

This schedule addresses only the fasteners required to anchor the window to achieve the rated design pressure up to the size limitations noted. It is not intended as a guide to the installation process and does not address the sealing consideration that may arise in different wall conditions. For the complete installation procedure, see the instructions packaged with the window or go to [www.jeld-wen.com](http://www.jeld-wen.com).

### DISCLAIMER:

This drawing and its contents are confidential and are not to be reproduced or copied in whole or in part or used or disclosed to others except as authorized by JELD-WEN Inc.



PROJECT ENGINEER: ---	DATE: 11/16/17	<h1 style="margin: 0;">JELD-WEN</h1>	3737 Lakeport Blvd Klamath Falls, OR. 97601 Phone: (800) 535-3936
DRAWN BY: A. MCMILLAN	SCALE: NTS		
CHECKED BY: J. GOOSSEN	TITLE: Premium Vinyl Awning Impact Window XXX - WZ2		
APPROVED BY: J. GOOSSEN			
PART/PROJECT No.: D014415			
IDENTIFIER No. 110-17-041	PLANT NAME AND LOCATION:	CAD DWG. No.: PremVinylAwning Cert	REV: A SHEET 2 OF 4

**MASONRY INSTALLATION**

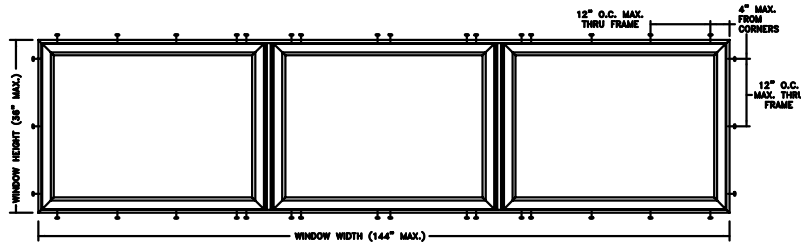

TYPICAL ELEVATION WITH FASTENER SPACING

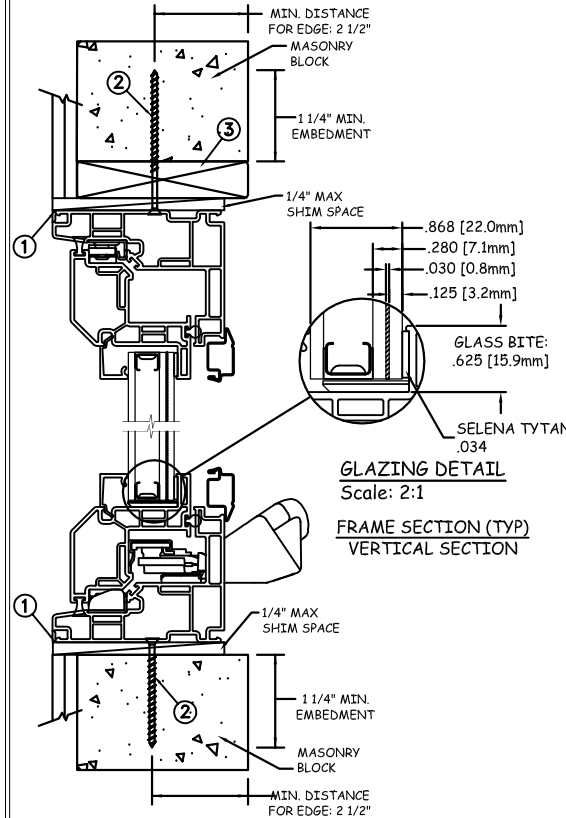

GLAZING DETAIL  
Scale: 2:1

FRAME SECTION (TYP)  
VERTICAL SECTION

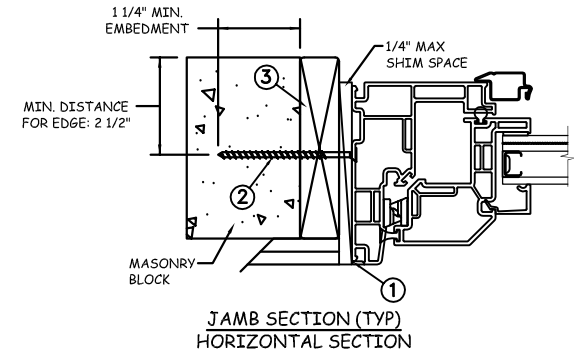

JAMB SECTION (TYP)  
HORIZONTAL SECTION

Max Frame	DP RATING	IMPACT
144 x 36	+50/-55	YES

WINDZONE 2

**Installation Notes:**

1. Seal flange/frame to substrate.
2. Use 3/16" Tapcon or equivalent fasteners through frame with sufficient length to penetrate a minimum of 1 1/4" into concrete or masonry at each location with a 2 1/2" min from edge distance. For concrete (min. = 3000psi) or masonry (min = 2000psi) (CMU shall conform to ASTM C90).
3. Host structure (wood buck, masonry, steel) to be designed and anchored to properly transfer all loads to the structure. The host structure is the responsibility of the architect or engineer of record for the project of installation.

**General Notes:**

1. The product shown herein is designed, tested and manufactured to comply with the wind load criteria of the adopted International Building Code(IBC), the International Residential Code(IRC), the Florida Building Code (FBC) excluding HVHZ and the industry requirement for the stated conditions.
2. All glazing shall conform to ASTM E1300.
3. At minimum, glazing shall be 3.2mm annealed - 11.8mm airspace - 3.2mm annealed - 0.8mm PVB Interlayer by Kurraray - 3.2mm annealed insulating glass.
4. Use structural or composite shims where required.

This schedule addresses only the fasteners required to anchor the window to achieve the rated design pressure up to the size limitations noted. It is not intended as a guide to the installation process and does not address the sealing consideration that may arise in different wall conditions. For the complete installation procedure, see the instructions packaged with the window or go to [www.jeld-wen.com](http://www.jeld-wen.com).

**DISCLAIMER:**

This drawing and its contents are confidential and are not to be reproduced or copied in whole or in part or used or disclosed to others except as authorized by JELD-WEN Inc.

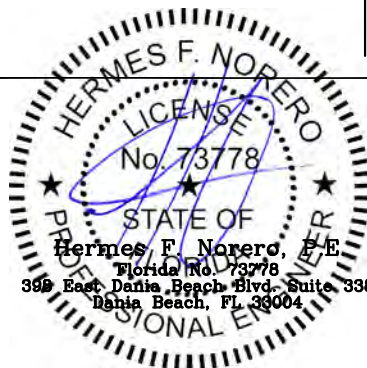

PROJECT ENGINEER: ---	DATE: 11/16/17
DRAWN BY: A. MCMILLAN	SCALE: NTS
CHECKED BY: J. GOOSSEN	TITLE: Premium Vinyl Awning Impact Window XXX - WZ2
APPROVED BY: J. GOOSSEN	
PART/PROJECT No.: D014415	
IDENTIFIER No. 110-17-041	PLANT NAME AND LOCATION:



3737 Lakeport Blvd  
Klamath Falls, OR. 97601  
Phone: (800) 535-3936

CAD DWG. No.: PremVinylAwning Cert	REV: A	SHEET 3 OF 4
---------------------------------------	-----------	-----------------

**STEEL INSTALLATION**

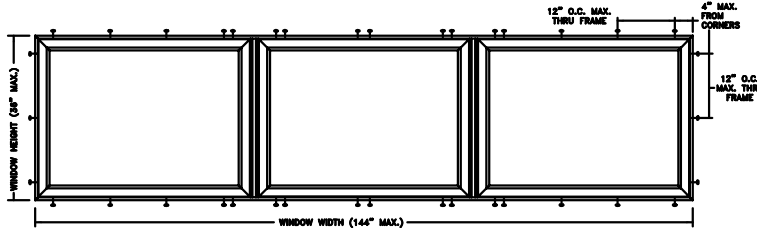

TYPICAL ELEVATION WITH FASTENER SPACING

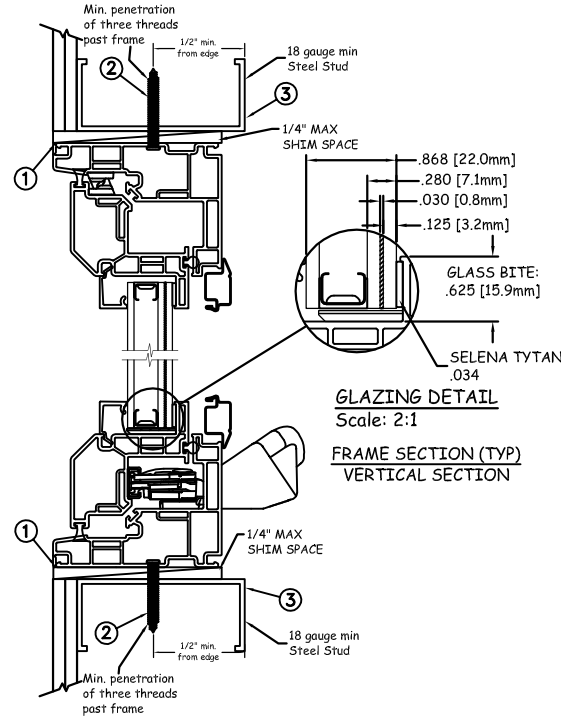

GLAZING DETAIL  
Scale: 2:1  
FRAME SECTION (TYP)  
VERTICAL SECTION

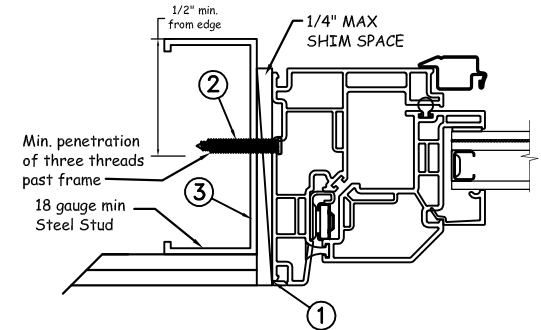

JAMB SECTION (TYP)  
HORIZONTAL SECTION

Max Frame	DP RATING	IMPACT
144 x 36	+50/-55	YES

WINDZONE 2

**Installation Notes:**

1. Seal flange/frame to substrate.
2. For anchoring into metal framing, use #8 TEK Self Tapping screws with sufficient length to achieve a minimum penetration of three threads past the frame thickness. Locate anchors as shown in elevations and installation details. Steel substrate min. 18ga., fy = 33 ksi.
3. Host structure (wood buck, masonry, steel) to be designed and anchored to properly transfer all loads to the structure. The host structure is the responsibility of the architect or engineer of record for the project of installation.

**General Notes:**

1. The product shown herein is designed, tested and manufactured to comply with the wind load criteria of the adopted International Building Code(IBC), the International Residential Code(IRC), the Florida Building Code (FBC) excluding HVHZ and the industry requirement for the stated conditions.
2. All glazing shall conform to ASTM E1300.
3. At minimum, glazing shall be 3.2mm annealed - 11.8mm airspace - 3.2mm annealed - 0.8mm PVB Interlayer by Kurraray - 3.2mm annealed insulating glass.
4. Use structural or composite shims where required.

This schedule addresses only the fasteners required to anchor the window to achieve the rated design pressure up to the size limitations noted. It is not intended as a guide to the installation process and does not address the sealing consideration that may arise in different wall conditions. For the complete installation procedure, see the instructions packaged with the window or go to [www.jeld-wen.com](http://www.jeld-wen.com).

**DISCLAIMER:**

This drawing and its contents are confidential and are not to be reproduced or copied in whole or in part or used or disclosed to others except as authorized by JELD-WEN Inc.

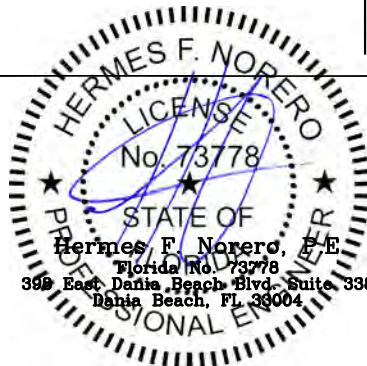

PROJECT ENGINEER: ---	DATE: 11/16/17	<b>JELD-WEN</b> 3737 Lakeport Blvd Klamath Falls, OR. 97601 Phone: (800) 535-3936
DRAWN BY: A. MCMILLAN	SCALE: NTS	
CHECKED BY: J. GOOSSEN	TITLE: Premium Vinyl Awning Impact Window XXX - WZ2	
APPROVED BY: J. GOOSSEN		
PART/PROJECT No.: D014415		
IDENTIFIER No.: 110-17-041	PLANT NAME AND LOCATION:	CAD DWG. No.: PremVinylAwning Cert
		REV: A
		SHEET 4 OF 4